

# OPTIONS TABLE

Base Part #	Total Stem Length	Color
SK1/4-ID SQFL [XX]5W	36	Matte White (WT)
	72*	Matte Black (BK)
	108*	

\*EX. **SK1/4-ID SQFL725WWT** -  
 (1) 36" Stem 1/4" IP I.D.-I.D.  
 (2) #60-1.5

\*EX. **SK1/4-ID SQFL1085BK** -  
 (2) 36" Stem 1/4" IP I.D.-I.D.  
 (3) #60-1.5

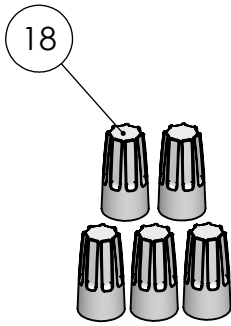

16

17

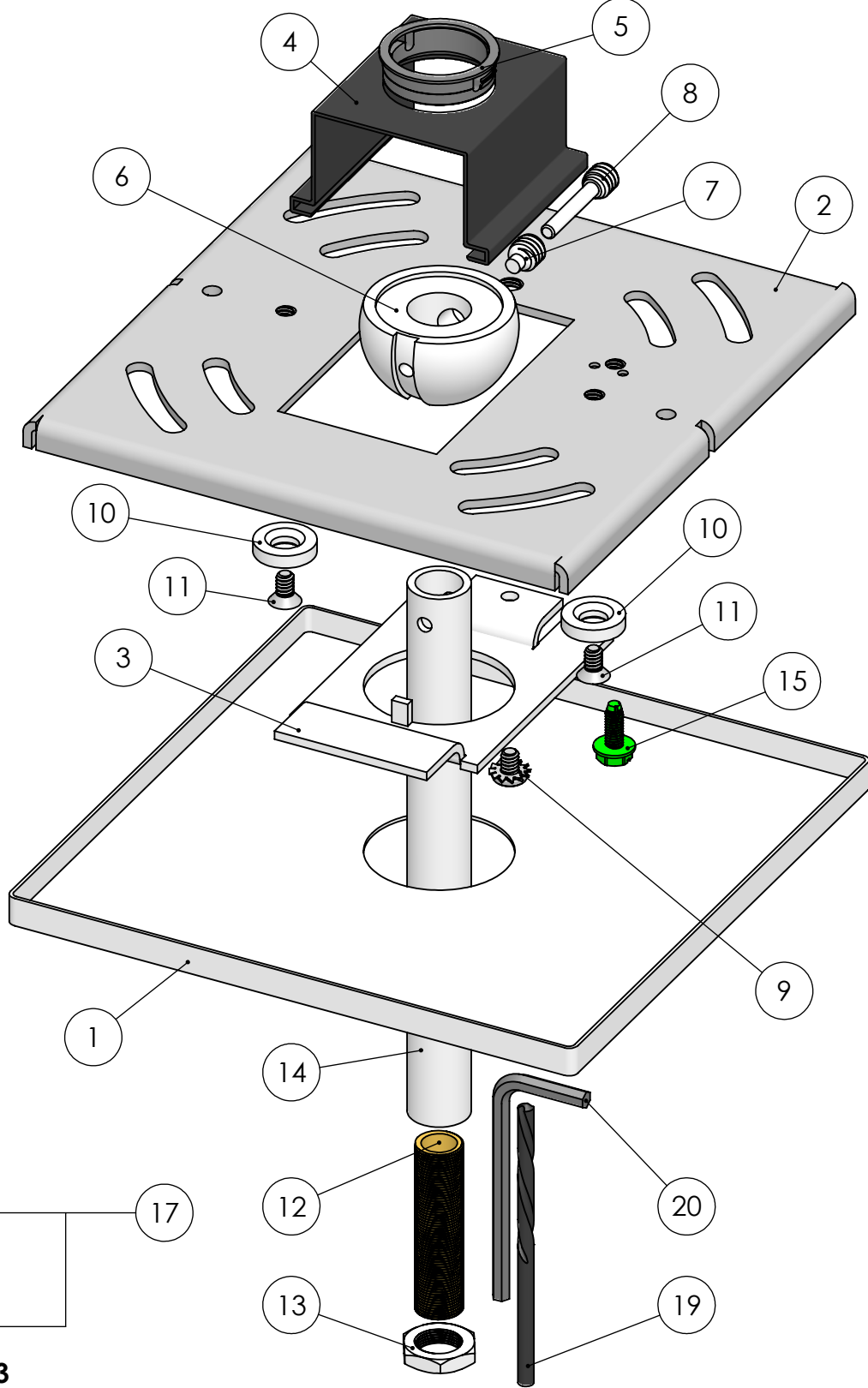

\*Reference Bill of Materials on Page 3

\*45° Swivel

This Document Contains Proprietary Data that is property of Pendant Systems which reserves all rights to it. Unauthorized use without authorization is prohibited.

## Pendant Systems

1670 Winchester Rd.  
 Bensalem, PA 19020  
 P-215-638-8552  
 F-215-638-8554  
[www.PendantSystems.com](http://www.PendantSystems.com)

UNLESS OTHERWISE SPECIFIED DIMENSIONS ARE IN BOTH INCHES & MILLIMETERS UNLESS OTHERWISE NOTED TOLERANCES:

LINEAR: XX= .02" XXX=  $\pm$ .010" ANGULAR:  $\pm$  1 Degree

FINISH:

TITLE:

SK 1-4-ID SQ FL [XX] 5W

DO NOT SCALE DRAWING

MATERIAL:

Part #

DEBUR AND BREAK SHARP EDGES

REVISION

DRAWN DATE: 7/5/17

Drawn By: MWR

SCALE: NTS

SHEET 1 OF 3

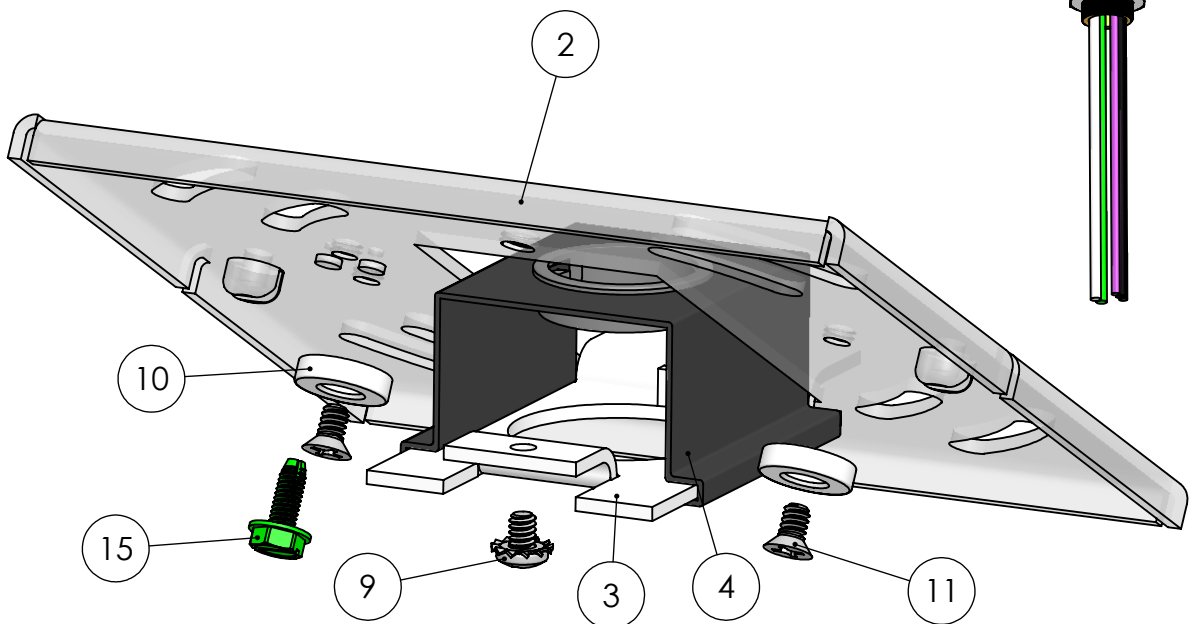
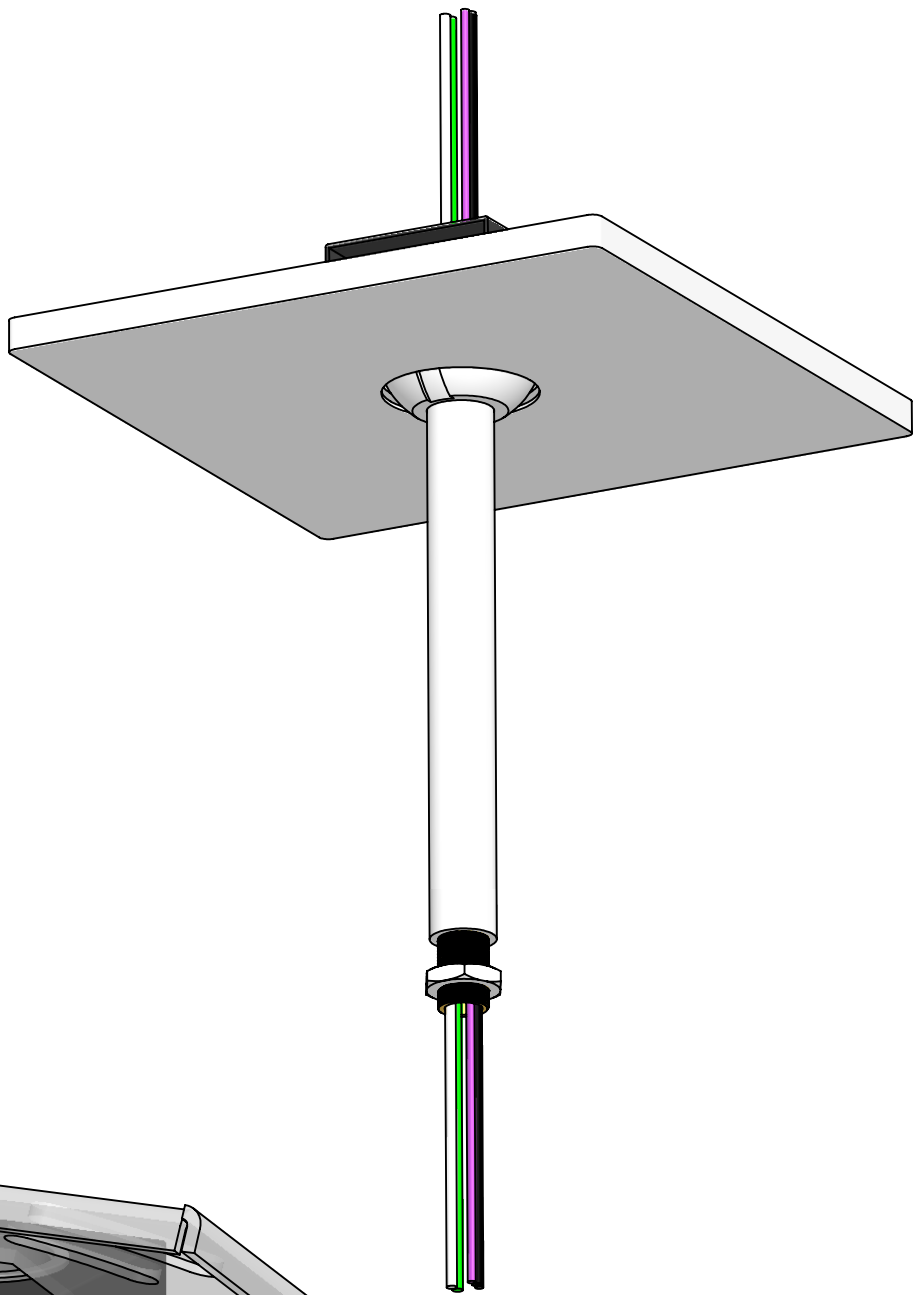

This Document  
Contains Proprietary  
Data that is property  
of Pendant Systems  
which reserves all  
rights to it.  
Unauthorized use  
without authorization  
is prohibited.

# Pendant Systems

1670 Winchester Rd.  
Bensalem, PA 19020  
P-215-638-8552  
F-215-638-8554  
[www.PendantSystems.com](http://www.PendantSystems.com)

UNLESS OTHERWISE SPECIFIED DIMENSIONS ARE IN BOTH INCHES & MILLIMETERS UNLESS OTHERWISE NOTED TOLERANCES:

LINEAR: XX= .02" XXX=  $\pm .010"$  ANGULAR:  $\pm 1$  Degree

FINISH:

TITLE: SK 1-4-ID SQ FL [XX] 5W Assembled

DO NOT SCALE DRAWING  
DEBUR AND BREAK SHARP EDGES

MATERIAL:

Part #

DRAWN DATE: 7/5/17

Drawn By: MWR

SCALE: NTS

SHEET 2 OF 3

REVISION

ITEM NO.	PART NUMBER	DESCRIPTION	QTY.
1	276B SQ	5" Canopy w/1.180" CH	1
2	MP Crossbar	Crossbar 14 Gauge Zinc Plated Steel 4.8" L x 4.8" W x .075" Material Thickness. GS inserted	1
3	MP Plate HB	Monopoint Plate for Half Ball for MP Crossbar 2.82" L x 1.650" W x .075" Material Thickness Half Ball Opening for #35,#34 and #147 Tapped 8/32" Hole Zinc Plated Steel	1
4	MP Swivel Clip	Mono Point Swivel Retaining Clip for MP- Plate HB Spring Steel	1
5	#237	.875" Hole Bushing .945" W x .750" I.D. x .250" H .063" Max Panel Thickness	1
6	#35ADJ	1/4" IP Slip Half Ball Bright Casting	1
7	#ADJ-SS	1/4" -20 Short (.350" Long) Socket Set Screw w/.125" DIA Point & 1/8" Allen Hex Head Pin for ADJ Series Half Balls	1
8	#SSS	1/4" -20 Socket Set Screw w/.125 DIA & 1/8" Allen Hex Head Pin for ADJ Series Half Balls	1
9	183	8/32" x 1/4" Philip Head Ext Sems Steel Zinc Screw	1
10	Magnet	#6 & #8 Magnet	2
11	271	6/32" x 1/4" L Flat Head Philips Machine Screw	2
12	60-1.5	60-1.5	[XX]
13	#133	1/8" IP x 9/16" O.D. x 1/8" Thick Zinc Plated	1
14	36" Stem 1-4IP I.D PH	36" Stem 1/4" IP w-18/" IP ID Thread on Bottom. Pin Hole on Top	1
15	#32	8/32 Green Ground Screw	1
16	18 AWG Single Conductor Wire	White, Black & Green. 42" L Coiled into Kit	3
17	22 AWG Single Conductor Wire	Purple & Gray. 42" L Coiled into Kit	2
18	72B Wire Nut	Ideal 72B	5
19	ADJ Tool Kit	Drill Bit 1/8" & Allen Wrench 1/8"	1

This Document  
Contains Proprietary  
Data that is property  
of Pendant Systems  
which reserves all  
rights to it.  
Unauthorized use  
without authorization  
is prohibited.

## Pendant Systems

1670 Winchester Rd.  
Bensalem, PA 19020  
P-215-638-8552  
F-215-638-8554  
[www.PendantSystems.com](http://www.PendantSystems.com)

UNLESS OTHERWISE SPECIFIED DIMENSIONS ARE IN BOTH INCHES &  
MILLIMETERS UNLESS OTHERWISE NOTED TOLERANCES:

LINEAR: XX= .02" XXX=  $\pm$ .010" ANGULAR:  $\pm$  1 Degree

FINISH:

TITLE:

Bill of Materials

DO NOT SCALE DRAWING

MATERIAL:

Part #

DEBUR AND BREAK SHARP EDGES

REVISION

DRAWN DATE: 7/5/17

Drawn By: MWR

SCALE: NTS

SHEET 3 OF 3